

PARTS LIST

Vacuum Cleaner

SC-B1221 (U.S.A.)

Specifications

Power source	: AC 120 V 60 Hz
Power consumption	: 12 A
Motor revolution	: 36,700 r.p.m.
Vacuum	: 23,000 Pa
Dimensions	: 14 - 1/4" X 14 - 3/16" X 45"
L X W X H	(362 X 360 X 1,143 mm)
Net weight	: 18 lbs. 5 ozs. (8.3 Kg)
Attachment	: Suction hose, Floor tool, Connection pipe, Crevice tool, Upholstery brush

PRODUCT CODE NO.

1 - 326 735 02 (LD)

Wiring Diagram

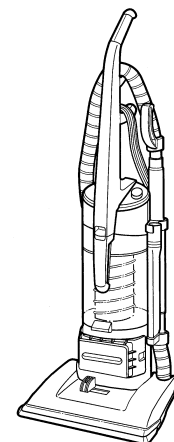
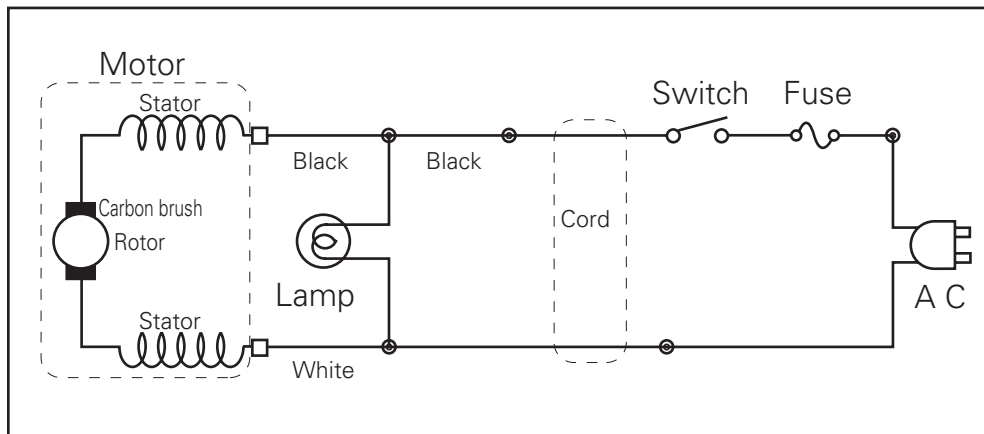

Exploded View

NOTE: The parts marked with \triangle have special characteristics of safety, if replace the \triangle mark parts, use only SANYO specified parts.

SC-B1221 (U.S.A.)

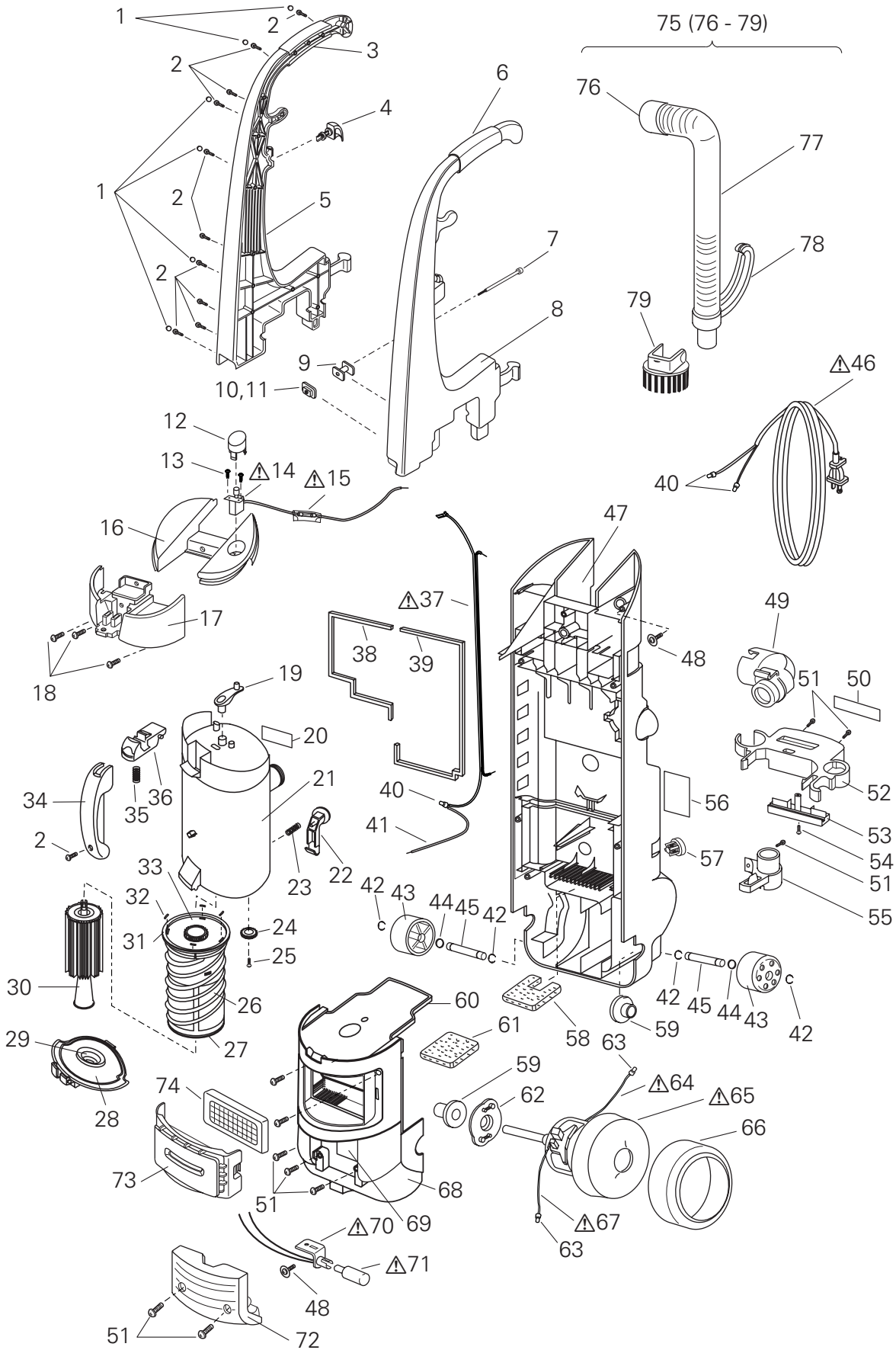

Exploded View

SC-B1221 (U.S.A.)

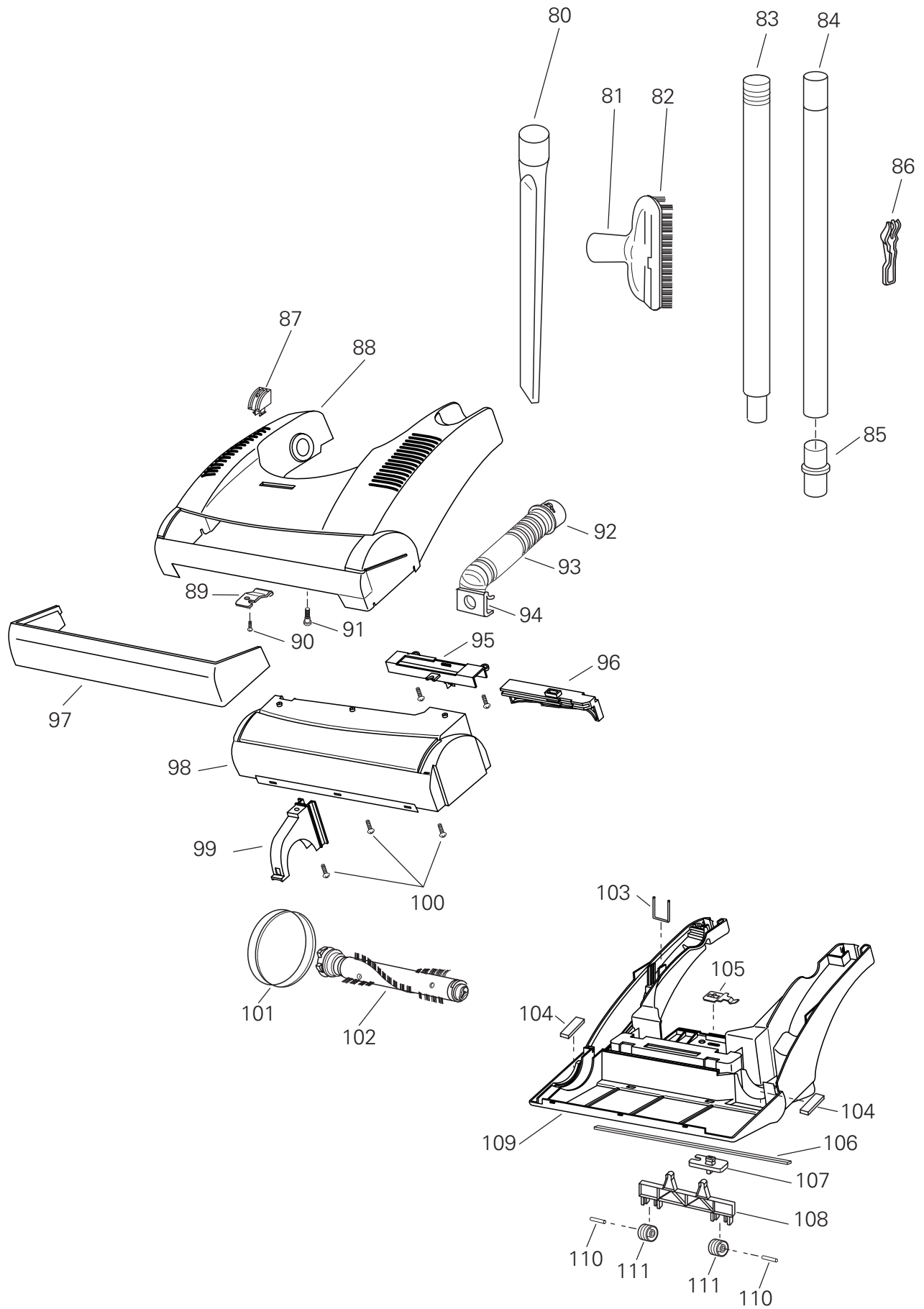

Parts List

NOTE: The parts marked with \triangle have special characteristics of safety,
if replace the \triangle mark parts, use only SANYO specified parts.

SC-B1221 (U.S.A.)

Key No.	Parts No.	Description	Q'ty	Key No.	Parts No.	Description	Q'ty
1	663 000 5750	INLAY PLUG (B-515)	6	58	663 000 6214	AIR INLET FILTER INNER	1
2	663 000 0939	SCREW (4X16)	11	59	663 000 2186	SLEEVE (NN-B)	2
3	663 000 5767	GRIP COVER RIGHT	1	60	663 000 6221	DUST BOX PACKING	1
4	663 000 5774	CORD HOOK (B-515)	1	61	663 000 6238	AIR INLET FILTER	1
5	663 000 5781	GRIP RIGHT (B-515)	1	62	663 000 4814	MOTOR CUSHION REAR	1
6	663 000 5798	GRIP COVER LEFT	1	63	663 000 2193	WIRE CONNECTOR (CE-5)	2
7	663 000 5804	SCREW	1	\triangle 64	663 000 2438	CORD ASSEMBLY (WHITE) L=350	1
8	663 000 5811	GRIP LEFT (B-515)	1	\triangle 65	663 000 3930	MOTOR COMP. (AC 120 V)	1
9	663 000 5828	GRIP SUPPLEMENT A	1	\triangle	663 000 0298	CARBON BRUSH ASSEMBLY	2
10	663 000 5835	GRIP SUPPLEMENT B	1	66	663 000 4821	MOTOR CUSHION FRONT	1
11	663 000 2285	NUT	1	\triangle 67	663 000 6245	CORD ASSEMBLY (BLACK) L=200	1
12	663 000 5842	SWITCH BUTTON (N3-99T)	1	68	663 000 6252	CASE FRONT (B-515)	1
13	663 000 2872	SCREW (3X10)	2	69	663 000 3411	SHIELD SHEET	1
\triangle 14	663 000 2896	SWITCH	1	\triangle 70	663 000 6269	LAMP HOLDER	1
\triangle 15	663 000 5859	FUSE ASSEMBLY (125V 12A)	1	\triangle 71	663 000 3398	LAMP (120V 15W)	1
16	663 000 5866	CASE ORNAMENT (NC-01)	1	72	663 000 6276	LENS	1
17	663 000 5873	CASE COVER (B-515)	1	73	663 000 6283	AIR OUTLET (B-520)	1
18	663 000 5880	SCREW (4X12)	3	74	663 000 6290	OUTLET FILTER	1
19	663 000 5897	DUSTER HANDLE A (N1-233)	1	75	663 000 6306	SUCTION HOSE COMP. KEYNO(76-79)	1
20	663 000 5903	CAUTION LABEL C	1	76	663 000 6313	HOSE JOINT PIPE B (NN-B)	1
21	663 000 5910	DUST BOX ASSEMBLY	1	77	663 000 6320	SUCTION HOSE (NN-B)	1
22	663 000 5927	CRAMP HOOK (N1-233)	1	78	663 000 6337	HOSE GRIP PIPE (NN-B)	1
23	663 000 5934	CRAMP SPRING B	1	79	663 000 6344	BRUSH BASE ASSEMBLY	1
24	663 000 5941	GEAR B	1	80	663 000 2476	CREVICE TOOL (NN-B)	1
25	663 000 2278	SCREW (4X17)	1	81	663 000 2483	UPHOLSTERY BRUSH BASE	1
26	663 000 5958	PRE FILTER ASS'Y A	1	82	663 000 5279	DUSTING BRUSH (NN-B)	1
27	663 000 5965	PACKING B	1	83	663 000 2490	CONNECTION PIPE A (NN-B)	1
28	663 000 5972	DUST FILTER COMP. B	1	84	663 000 2506	CONNECTION PIPE B (NN-B)	1
29	663 000 5989	PACKING A	1	85	663 000 6351	CONNECTION PIPE C (NN-B)	1
30	663 000 5996	DUST FILTER COMP. A	1	86	663 000 0892	DUSTER ARM	1
31	663 000 6009	PACKING C	1	87	663 000 6368	LEVER KNOB (N3-99T)	1
32	663 000 6016	SPACER	4	88	663 000 6375	CASE UPPER (B-515)	1
33	663 000 6023	GEAR A	1	89	663 000 2551	LEAF SPRING	1
34	663 000 6030	HANDLE (B-515)	1	90	663 000 2292	SCREW (4X14)	1
35	663 000 6047	CRAMP SPRING A	1	91	663 000 2568	SCREW	1
36	663 000 6054	CRAMP LEVER (N3-99T)	1	92	663 000 6313	HOSE JOINT PIPE B (NN-B)	1
\triangle 37	663 000 6061	CORD ASSEMBLY	1	93	663 000 6382	SUCTION HOSE (NN-B)	1
38	663 000 6078	AIR SPREADER D	1	94	663 000 6399	AIR INLET (NC-01)	1
39	663 000 6085	AIR SPREADER C	1	95	663 000 6405	LEVER COVER	1
40	663 000 0700	WIRE CONNECTOR (CE-2)	4	96	663 000 6412	LEVER (B-515)	1
41	663 000 6092	LEAD WIRE (BLACK) L=300	1	97	663 000 6429	BUMPER	1
42	663 000 2131	RING E6	4	98	663 000 6436	CASE COVER FRONT (B-520)	1
43	663 000 6108	WHEEL REAR (NN-B)	2	99	663 000 6443	BELT COVER	1
44	663 000 2155	WASHER Z 7.2X12X0.5	2	100	663 000 0847	SCREW (4X16)	5
45	663 000 6115	SHAFT REAR	2	101	663 000 2582	BELT	1
\triangle 46	663 000 5668	POWER CORD (U2)	1	102	663 000 6450	ROTARY BRUSH COMP.	1
47	663 000 6122	CASE REAR (NC-01)	1	103	663 000 2599	BELT COVER D	1
48	663 000 2278	SCREW (4X17)	2	104	663 000 6467	AIR SPREADER A	2
49	663 000 6139	HOSE JOINT PIPE A (NN-B)	1	105	663 000 2612	LEAF SPRING D	1
50	663 000 6146	LABEL	1	106	663 000 6474	SUCTION KEEPER (NN-B)	1
51	663 000 0243	SCREW (4X20)	10	107	663 000 2650	LEVER	1
52	663 000 6153	ATTACHMENT SUPPORTER A	1	108	663 000 6481	BOTTOM PLATE (NN-B)	1
53	663 000 6160	ATTACHMENT SUPPORTER B	1	109	663 000 6498	WHEEL HOLDER (NN-B)	1
54	663 000 6177	SCREW (3X16)	1	110	663 000 6504	SHAFT FRONT	2
55	663 000 6184	EXTENSION PIPE RETAINER	1	111	663 000 2636	WHEEL FRONT	2
56	663 000 6191	NAME PLATE	1		663 000 6511	INSTRUCTION MANUAL	1
57	663 000 6207	TRANSMISSION ASSEMBLY	1				

COLOR CODE: B-515/B-520(BLUE), N3-99T(SILVER), N1-233/NC01(GRAY), NN-B(BLACK)

For Parts or Service Contact
SANYO FISHER SERVICE CORPORATION.
21605 Plummer Street,
Chatsworth, CA 91311